

2MP IP Indoor Multi-Sensor NVR w/ WI-FI

The 3xLOGIC Indoor Multi-Sensor NVR (VX-2S-CPIR-W) is a cube style, 2MP camera that goes far beyond being an IP video camera. The Multi-Sensor boasts the ability to host VIGIL Server, allowing the camera to record video to the onboard SD card, with full search capabilities in VIGIL Client and in the View Lite II and infinias mobile apps. Additionally, use VIGIL Central Management (VCM) to monitor online/offline and recording status as well as number of days of recorded footage. A true all-in-one solution, built-in Passive Infrared (PIR) sensors, 2-way audio with VIGIL Server, and digital I/O allow the Multi-Sensor to be an alarm annunciator, audio system, and video recorder in one, small unit.

Using combinations of features, integrators can unlock the true potential of the Multi-Sensor. Combine PIR and pixel-based motion detection to decrease false motion alarms. Use the onboard VIGIL Server combined with a VIGIL Server onsite for redundant recording. When an alarm is triggered into the digital I/O, use 2-way audio to communicate with site. Receive push notifications to the View Lite II mobile app from any alarm using VIGIL Connect. With the optional glass break analytic enabled the VX-2S-CPIR-W can detect six different glass types up to 25' away. A self-test feature confirms the Multi-Sensor is capable of listening for and detecting glass breaking sounds.

The Multi-Sensor was also designed with the installer in mind. Use the 3xLOGIC All-in-One PC Setup Utility for auto-detection and setup or the mobile VSX Setup app for a simple Scan-and-Setup interface. These tools along with the ability to connect with wireless networks using WPS, allow a single installer to get the camera positioned and recording in a matter of minutes, instead of hours.



Key Features and Benefits	
Lens	2.8mm @ F2.0
Resolution (Megapixels)	2
1920 x 1080 Resolution @ 30fps	✓
H.264/MJPEG	✓
Angle of View	85°
IR Range	Up to 10 Meters
Digital Wide Dynamic Range	✓
IR Cut Filter with Auto Switch	✓
Glass Break Detection	Optional
ONVIF (Profile-S)/PSIA/CGI/ISAPI	✓
3 Year Warranty	✓

CAMERA

Image Sensor:	1/2.8 inch Progressive Scan CMOS
Lens:	2.8mm @ F2.0
Min. Illumination:	0.028 Lux @ (F2.0) AGC on; 0 Lux w/ IR
IR Range:	Up to 10 Meters
Angle of View:	85°
PIR Range:	Up to 10 Meters; 80° Angle of View
Day/Night:	IR cut filter with auto switch
Shutter Times:	1/3 seconds to 1/100,000 seconds

COMPRESSION STANDARD

Video Compression:	H.264, MJPEG
Video Bit Rate:	32 Kbps - 12 Mbps
Audio Compression:	G.711/G.722.1/G.726/MP2L2/PCM
Audio Bit Rate:	64Kbps(G.711) / 16Kbps(G.722.1) / 16Kbps(G.726) / 32-192Kbps(MP2L2)

IMAGE

Max. Image Resolution:	1920 x 1080
Frame Rate:	60Hz: 30fps
Digital Noise Reduction:	3D DNR
Wide Dynamic Range:	Yes; Digital
Image Setting:	Rotate mode, Saturation, Brightness, Contrast, Sharpness, AGC, ROI

FUNCTIONS

Alarm Triggers:	Intrusion detection, Motion detection, Dynamic analysis, Tampering alarm, Network disconnect, IP address conflict, Storage exception
Local Storage:	Built-in Micro SD, SDHC SDXC card slot, up to 128GB
Security:	One-key reset, Flash-prevention, Dual stream, Heartbeat, Password protection, Privacy mask, Watermark, IP address filtering, Anonymous access
Protocols:	TCP/IP, ICMP, HTTP, HTTPS, FTP, DHCP, DNS, DDNS, RTP, RTSP, RTCP, PPPoE, NTP, UPnP, SMTP, SNMP, IGMP, 802.1X, QoS, IPv6, Bonjour
System Compatibility:	ONVIF (Profile S), PSIA, CGI, ISAPI

PHYSICAL

Working Temperature:	-30°C - 60°C (-22°F - 140°F); Humidity 95% max
Dimensions (inches):	2.85" x 3.64" x 5.25"
Dimensions (mm):	72.3 x 92.34 x 133.3
Weight:	0.88 lbs. / 400 g

ELECTRICAL

Power Supply:	12V DC ±10%; PoE (802.3af)
Power Consumption:	5W Max

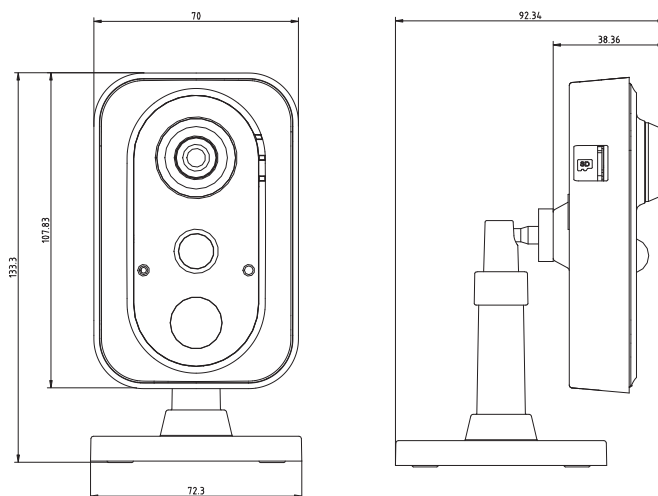

UNIT:mm

INTERFACE

Communication:	1 RJ45 10M/100M Ethernet port
Audio Input:	Built-in Microphone
Audio Output:	Built-in Speaker
Alarm Input:	1 - Channel Signal Input
Alarm Output:	1 - Channel Signal Relay Output

WI-FI

Wireless Standard:	IEEE802.11b, 802.11g, 802.11n
Frequency Range:	2.4 GHz ~ 2.4835 GHz
Channel Bandwidth:	20/40MHz Support
Protocols:	802.11b: CCK, QPSK, BPSK; 802.11g/n: OFDM
Security:	64/128bit WEP, WPA/WPA2, WPA-PSK/WPA2-PSK, WPS
Wireless Range:	50m (Dependant Upon Environment)

WARRANTY

Three (3) Year Return to Depot Parts and Labor Warranty

CERTIFICATIONS

FCC, CE, UL, UL Canada

PART NUMBER

VX-2S-CPIR-W:	2MP Indoor IP Multi-Sensor NVR w/ WI-FI
-S	VIGIL Server Stand-Alone Software License
-S64	VIGIL Server Stand-Alone Software License with 64GB SD Storage
-GB	Glass Break Analytic License

Stand-Alone Server features can easily be added to the camera after installation. Contact your 3xLOGIC Representative for details.