

## VISIX Pendant Mount Bracket Kit - BC10 or BC06

### Mount Specifications

<b>Material</b>	Aluminum
<b>Color</b>	White
<b>Dimensions (Head)</b>	140.8mm x 91.5mm
<b>Dimensions (Case)</b>	100mm x 44mm
<b>Weight (with Pole)</b>	~700g



### Dimensions

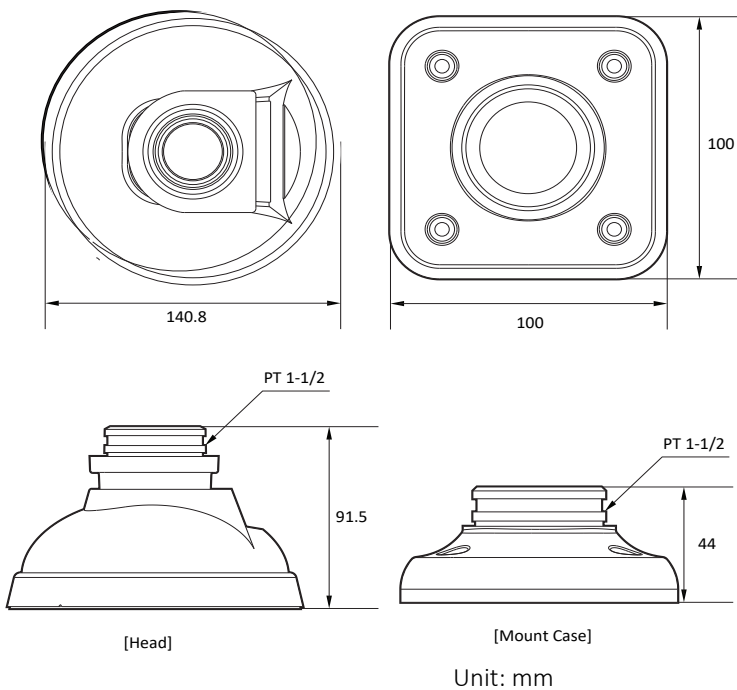

### Instructions

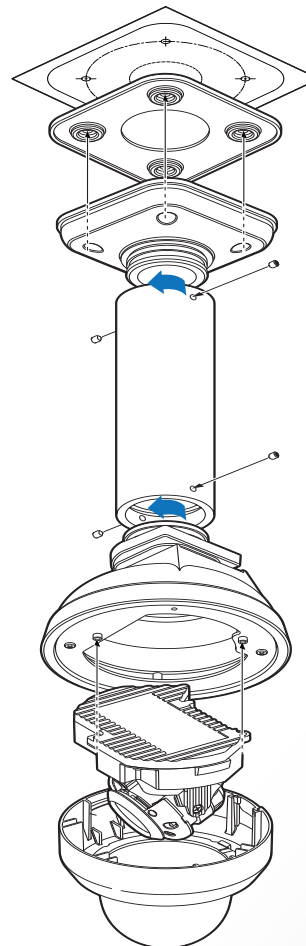

- 1 Using provided template sheet, make holes on the ceiling panel in the desired location.
- 2 Attach the Bottom pad and the Mount case, and then use a screw to tighten the ceiling.
- 3 Turn the pole to the Mount case and the Head to engage.  
After binding, secure with Set Screw.  
☒ Pole is purchased separately.
- 4 After the engagement is completed, use the mount screw to engage the camera and bracket.
- 5 Finally, insert the Dome Cover into the camera to complete it.