

VISIX Pendant Mount - BC09

Mount Specifications

Material	Aluminum
Color	White
Dimensions	154mm x229mm



VX-PM-BC09 Dimensions

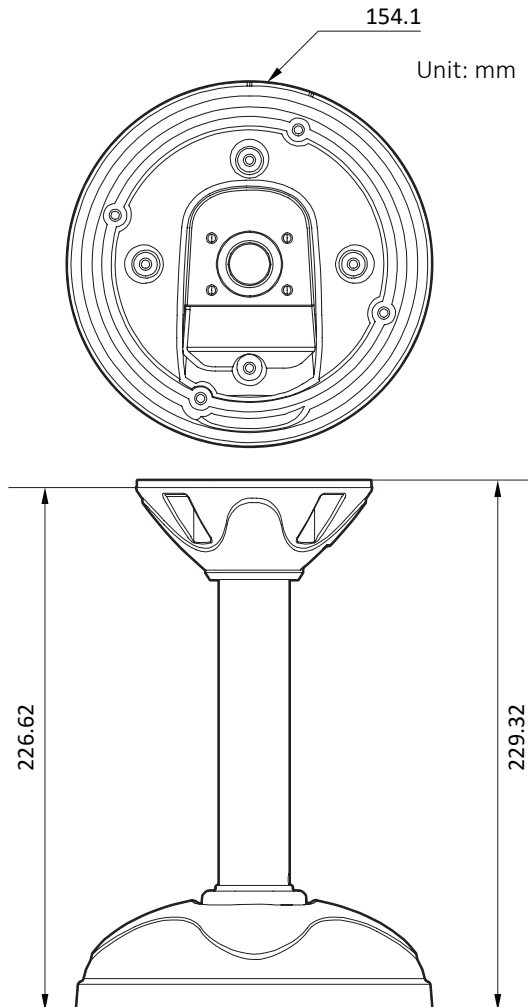

Camera Installation

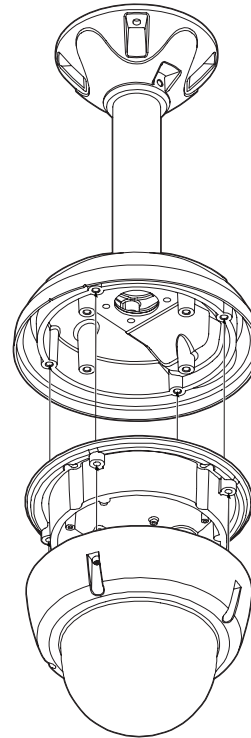

- 1 Attach the Mount Pad and mount the unit to the ceiling.
- 2 Connect the cable.
- 3 Attach the camera base to the mount.
- 4 After adjusting the camera, attach the upper case to complete the installation.