

VISIX Pendant Mount - VX-PM-BC15

Mount Specifications

Material	Aluminum
Color	White
Dimensions	220mm x 276mm
Weight	1300g

Note: Pole can be removed and a custom length 1 1/2" female threaded pole can be added in its place.



VX-PM-BC15 Dimensions

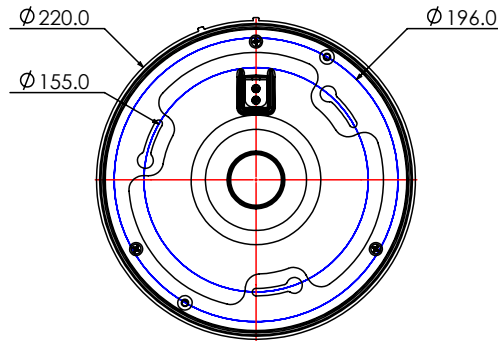
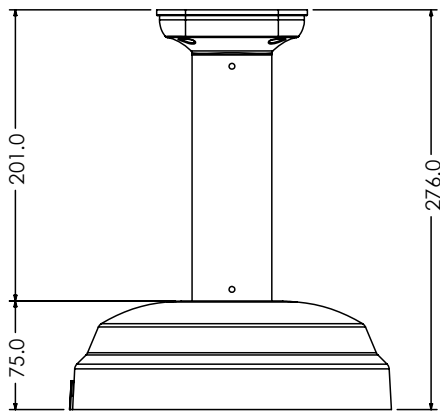

Unit: mm

